

Name DEL ID # _____

Section # _____ TA Name _____

Fill in your name, student ID # (not your social security #), and section # (under ABC of special codes) on the Scantron sheet. Fill in the letters given for the first 5 questions on the Scantron sheet. These letters determine which version of the test you took, and it is very important to get this right. Make sure your exam has questions 6—25.

1. B

2. C

3. D

4. D

5. D

6. Given that there are 5280 feet in a mile, how many seconds does it take a car moving at 35 mi/hr to travel 4000 feet?

a. 177 s

b. 136 s

c. 168 s

 d. 77.9 s

e. 26.5 s

CONVERT TO FT/SEC

$$35 \frac{\text{MI}}{\text{HR}} \times 5280 \frac{\text{FT}}{\text{MI}} \times \frac{1 \text{ HR}}{3600 \text{ SE}} = 51.33 \text{ FT/S}$$

$$x = vt; \quad t = x/v = 4000 \text{ FT} / 51.33 \text{ FT/S} = 77.9 \text{ S}$$

7. The duration of a physics 103 lecture is

a. 3 ms

 b. 3 ksc. 3×10^2 sd. 3×10^{-2} se. 3×10^{-3} s

$$50 \text{ MIN} \times 60 \text{ S/MIN} = 3000 \text{ S} = 3 \times 10^3 \text{ S}$$

$$= 3 \text{ KS}$$

$$(1 \text{ k} = 1000 = 10^3)$$

8. Which of the following would unambiguously indicate a quantity accurate to three significant digits?

a. 360 — 2 (or MAYBE 3)

b. 3.6×10^2 — 2

c. 360.0 — 4

 d. 3.60×10^2 e. 36×10^1 — 2

9. If the tangent of an angle is 0.75, what is the sine of that angle?

- a. 2.28×10^{-4}
- b. 0.75
- c. 0.0131
- d. 0.8
- e. 0.6

$$\theta = \tan^{-1} 0.75 = 36.87^\circ$$
$$\sin \theta = 0.6$$

10. If the hypotenuse of a right triangle is 1.20 m and one of the angles is 25° , the sum of the other two sides of the triangle is

- a. 1.20 m
- b. 1.59 m
- c. 1.26 m
- d. 2.54 m
- e. 2.40 m

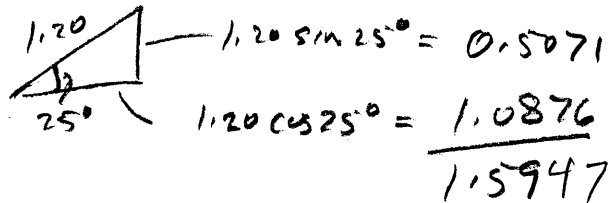

11. Which one of the following statements is false regarding a ball thrown vertically upward (ignore air resistance):

- a. The velocity is zero when it reaches its maximum height. TRUE
- b. The acceleration is downward when it reaches its maximum height. TRUE
- c. The acceleration is opposite the velocity just after it is thrown. TRUE
- d. The velocity and the acceleration are in the same direction as it returns. TRUE
- e. The velocity is the same when it returns as when it was released. FALSE!

12. The reaction time for most people is about

- a. 0.5 s
- b. 250 ms
- c. 0.02 s
- d. 400 ms
- e. 100 ms

$\sim 250 \text{ ms}$ - FROM LECTURE & LAB M1-6

(SPEED IS SAME
VELOCITY HAS DIFF.
DIRECTION)

13. An object released from rest at a height of 1.5 m above the ground will hit the ground after what time?

- a. 0.306 s
- b. 0.153 s
- c. 0.276 s
- d. 0.553 s
- e. 0.526 s

$$x = \frac{1}{2}gt^2 \quad t = \sqrt{\frac{2x}{g}} = \sqrt{\frac{3}{9.8}} = 0.553$$

14. With what minimum speed must you throw a ball for it to reach a height of 7 m above the point at which it leaves your hand?

- a. 137 m/s
- b. 68.6 m/s
- c. 8.28 m/s
- d. 5.86 m/s
- e. 11.7 m/s

MINIMUM SPEED IS SPEED FOR WHICH 7M IS MAXIMUM HEIGHT. IF v_0 IS THIS SPEED, AT MAX. HT. $v_f = 0$
 $v_f^2 = v_0^2 + 2ax$ SO $0^2 = v_0^2 + 2(-9.8)7$
 $v_0 = \sqrt{137.2} = 11.7 \text{ m/s}$

15. Which one of the following statements is true for an object released from rest, ignoring air resistance?

- a. It falls the same distance in the same interval of time. FALSE (IT'S GOING FASTER LATER)
- b. It falls faster if it heavier. FALSE
- c. The distance it falls is proportional to the square of time. TRUE
- d. The distance it falls is proportional to the time. FALSE $\rightarrow x = \frac{1}{2}gt^2$
- e. Its velocity is constant while falling. FALSE $v = -gt$

MEANS, eg., 1 SEC NOW VS. 1 SEC LATER.

16. An airplane flies due east for 100 km and then turns south and flies another 200 km. What is its displacement vector?

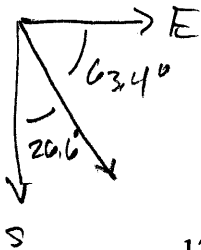

- a. 224 km, 26.6° east of south
- b. 300 km, 63.4° south of east
- c. 224 km, 60° south of east
- d. 300 km, 60° south of east
- e. 224 km, 63.4° east of south

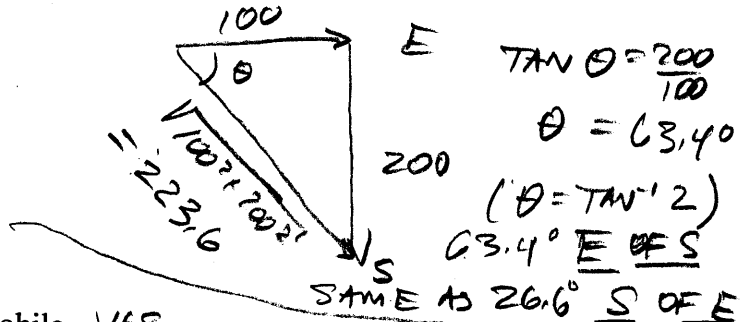

17. Which of the following is a vector?

- a. The acceleration of an automobile YES \rightarrow MAGNITUDE AND DIRECTION
 - b. The horizontal component of velocity NO
 - c. The speed of a moving object NO
 - d. The distance from Madison to Milwaukee. NO
 - e. The magnitude of a displacement NO
- ONLY MAGNITUDE

18. With what initial speed must you hit a golf ball for it to land 50 m away if its initial angle is 20° above the horizontal?

- a. 762 m/s
- b. 55.2 m/s
- c. 27.6 m/s
- d. 9.44 m/s
- e. 25.9 m/s



$v_{0y} = v_0 \sin 20^\circ$

$v_{0x} = v_0 \cos 20^\circ$

TIME TO MAX HT = TIME TO ZERO VELOCITY

$0 = v_f = v_{0y} + (-g)t_{max}$

$v_{0y} = g t_{max}$ $t_{max} = \frac{v_{0y}}{g}$

\rightarrow TOTAL FLIGHT TIME = 2 X TIME TO MAX HEIGHT

$t = 2t_{max} = \frac{2v_{0y}}{g} = \frac{2v_0 \sin 20^\circ}{g}$

$50 = x = v_{0x} t = v_0 \cos 20^\circ \left(\frac{2v_0 \sin 20^\circ}{g} \right)$

$v_0^2 = \frac{50g}{2 \cos 20^\circ \sin 20^\circ} = 762.3$ $v_0 = 27.6 \text{ m/s}$

19. In the monkey and hunter demo in lecture where the monkey begins falling at the instant the gun is fired, the best strategy for the hunter is to

- a. Aim slightly above the monkey
- b. Aim slightly below the monkey
- c. Aim horizontally
- d. Aim directly at the monkey
- e. Wait for the monkey to hit the ground and try to catch him

20. An automobile traveling 40 m/s drives off the edge of a cliff and hits the ground 100 m horizontally from the cliff. How high is the cliff?

- a. 25.0 m
- b. 28.1 m
- c. 12.3 m
- d. 122.5 m
- e. 30.6 m

$$100 \text{ m} = x = v_0 x t = 40 t \quad t = \frac{100}{40} = 2.5 \text{ s}$$

$$y = \frac{1}{2} g t^2 = \frac{1}{2} (9.8) (2.5)^2 = 30.625$$

21. Two carts roll without friction along a horizontal surface in response to a force as shown. What is the tension T in the string connecting the carts?

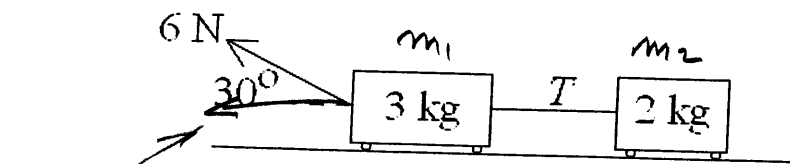

TOTAL HORIZ. FORCE

- a. 1.20 N
- b. 5.20 N
- c. 1.04 N
- d. 6.00 N
- e. 2.08 N

$$m = m_1 + m_2$$

TOTAL MASS = 5 kg
 TOTAL HORIZONTAL FORCE = $6 \cos 30^\circ = 5.196 \text{ N}$

$$a = F/m = \frac{5.196 \text{ N}}{5 \text{ kg}} = 1.039 \text{ m/s}^2$$

HORIZONTAL FORCE ON 2kg IS $T = m_2 a$
 $T = 2 \text{ kg} \times a = 2 \times 1.039 = 2.078 \text{ N}$

22. A block has a coefficient of kinetic friction $\mu = 0.2$ with an inclined plane that it is sliding down as shown. What is its acceleration parallel to the plane?

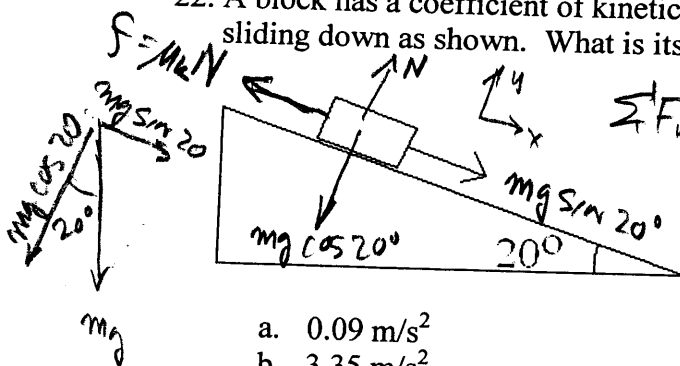

- a. 0.09 m/s^2
- b. 3.35 m/s^2
- c. 1.39 m/s^2
- d. 1.51 m/s^2
- e. 1.96 m/s^2

$$\sum F_y = N - mg \cos 20^\circ = 0$$

$$N = mg \cos 20^\circ$$

$$\sum F_x = mg \sin 20^\circ - f = ma$$

$$mg \sin 20^\circ - \mu (mg \cos 20^\circ) = ma$$

$$a = g (\sin 20^\circ - \mu \cos 20^\circ)$$

$$a = 9.8 (\sin 20^\circ - 0.2 \cos 20^\circ)$$

$$a = 1.51 \text{ m/s}^2$$

(HERE WE CONSIDER THE TOTAL FORCE IN THE DIRECTION OF THE ACCELERATION OF BOTH BLOCKS)

23. In the pulley arrangement below, what is the magnitude of the acceleration of the 8-kg block if friction is ignored?

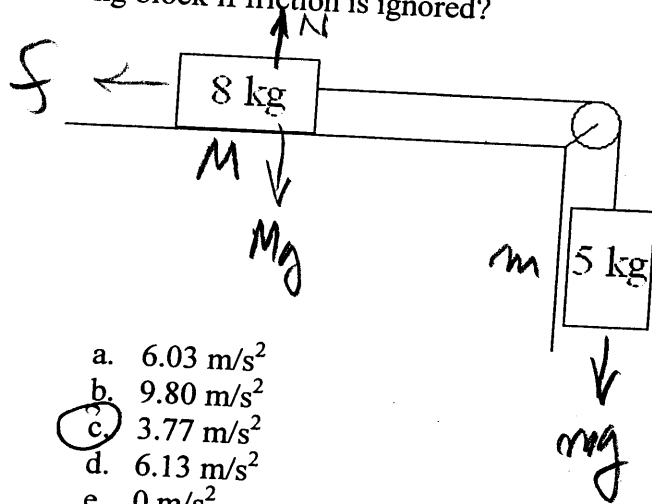

$f = 0$
 TOTAL FORCE = mg
 $= 5 \times 9.8$
 $= 49 \text{ N}$
 TOTAL MASS = 13 kg
 $a = F / (m + M) = 49 / 13$
 $a = 3.77 \text{ m/s}^2$

- a. 6.03 m/s^2
 b. 9.80 m/s^2
 c. 3.77 m/s^2
 d. 6.13 m/s^2
 e. 0 m/s^2

24. If the 8-kg block in the previous problem accelerates at 3 m/s^2 to the right, what is the coefficient of kinetic friction between the block and the table?

- a. 0.293
 b. 0.421
 c. 0.128
 d. 0.497
 e. 0.204

TOTAL FORCE NOW IS $mg - f = mg - \mu_k N$
 For 8 kg, $\sum F_y = N - Mg = 0$ SO $N = Mg$
 $mg - \mu_k Mg = (m + M)a = 13 \cdot 3 = 39$
 $49 - \mu_k Mg = 39$ $\mu_k Mg = 10$ $\mu_k = 0.128$

25. When you lift an object off the floor, which one of the following statements is false?

- a. You exert an upward force on the object TRUE
 b. The object exerts a downward force on you TRUE
 c. The Earth exerts a downward force on the object TRUE (GRAVITY)
 d. The object exerts a downward force on the Earth FALSE (UPWARD)
 e. The object exerts an upward force on the Earth TRUE